

## Breeding Station ProSift MINI Breeding station 1 module

ITEM # \_\_\_\_\_

MODEL # \_\_\_\_\_

NAME # \_\_\_\_\_

SIS # \_\_\_\_\_

AIA # \_\_\_\_\_

**729286 (BRDSTIMS)**

 Breeding station 1 module  
 ProSift mini

### Short Form Specification

**Item No.** \_\_\_\_\_

The breeding station is an optimized multifunctional workstation (blender-breader-sifter) designed to improve the hand breeding phase reducing the operative costs.

It is provided by a new automatic breeding sifting mechanism.

The benefits are:

- Improved taste and consistent food results thanks to integrated automatic processes.
- Improved productivity and flour quantity saving
- Consistent food quality
- Optimized staff workflow
- Functional use of space
- Advanced ergonomics
- Guaranteed safety and hygiene
- Environment-friendly solution"

### Main Features

- Breeding system with high resistant plastic basins. The plastic basins are easily removable from the work top thanks to 2 integrated handles. The bottom part of the basins has a rectangular hole, with cap, for discharging the flour into the intermediate hopper and finally into the sifting drum to be automatically filtered. The cap is designed to avoid unintentional removal during the breeding phase.
- Patented automated dual action sifting system for maximum sifting efficiency and highest food quality time after time. Dual action drum removes unwanted dough balls keeping flour cleaner and frying oil lasting longer: internal drum design with helix profile expels the residual dough balls into the dedicated dough balls catcher with no need to stop operations.
- Sifting cycle with zero downtime allows operator to bread product while the sifting cycle of previous batch is ongoing.

### Construction

- Mainly construction in A304 stainless steel for everlasting operation in all working environment.
- All materials and plastic parts in contact with flour and food are in compliance with Food Contact regulations and dishwasher safe.
- No consumable plastic parts.
- Silent operations allows installations also close to front of house.
- Equipped with 4 wheels, 2 with brake.
- The unit is equipped with a 2m length electrical cord.
- IPX3 protected.
- Manufactures corresponds to international certification ISO 9001, ISO14001, OHSAS 18001, ISO 5001.
- CE approved (Machine Directive), CB extension.

**APPROVAL:** \_\_\_\_\_

**Included Accessories**

- 1 of Lug cover for breeding station PNC 880533
- 1 of Lug collar PNC 880540
- 1 of White lug with rubber plug for breeding station PNC 881183
- 1 of Grey lug with rubber plug for breeding station PNC 881184
- 1 of Plastic scraper for breeding station PNC 881215

**Optional Accessories**

- Lug cover for breeding station PNC 880533
- Horizontal tray support for breeding station PNC 880535
- Inclined tray support for breeding station PNC 880536
- Lug collar PNC 880540
- White lug with rubber plug for breeding station PNC 881183
- Grey lug with rubber plug for breeding station PNC 881184
- Rubber plug for Breeding Station lug PNC 881185
- Soaking basket PNC 881207
- Plastic scraper for breeding station PNC 881215
- Cleaning brush Ø110mm for breeding station PNC 881216
- Kit of 4 nylon swabs Ø9mm for breeding station PNC 881217
- Multipurpose brush for breeding station PNC 881218
- Cleaning kit for breeding station PNC 881219
- Stainless steel water insert pan for breeding station PNC 881249

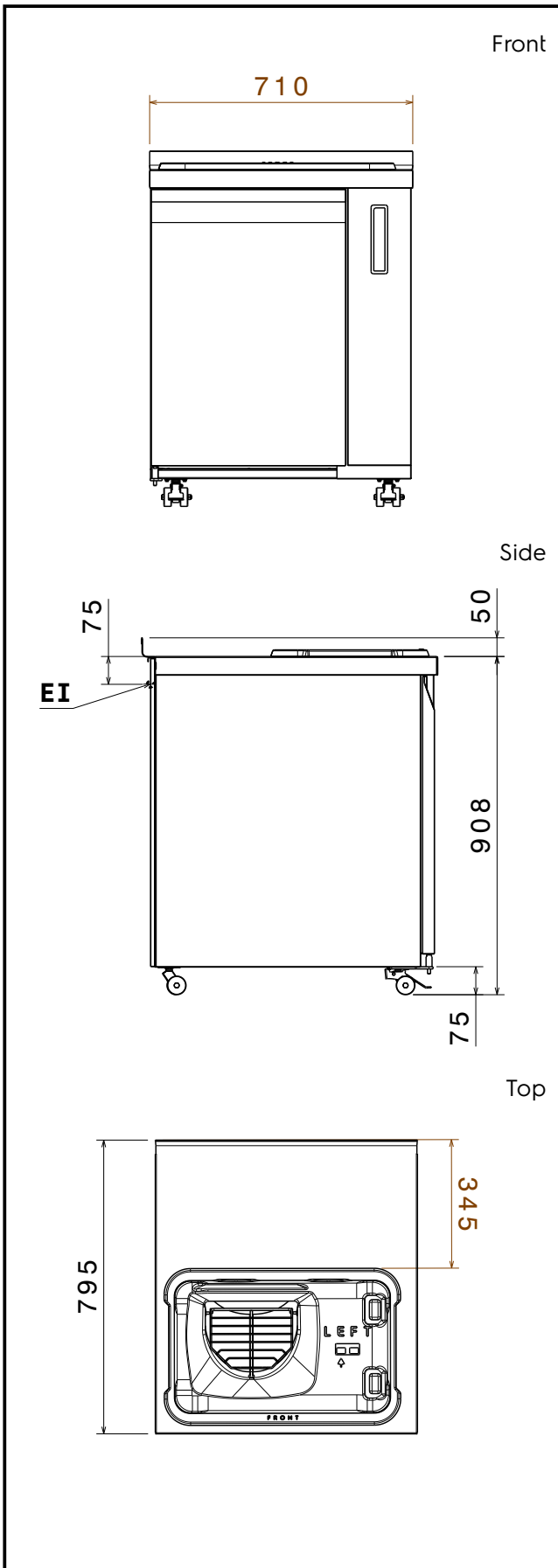

### Electric

Supply voltage:

729286 (BRDSTIMS) 220-240 V/1 ph/50/60 Hz

Electrical power max.:

0.05 kW

### Key Information:

External dimensions, Width: 710 mm

External dimensions, Depth: 795 mm

Weight: 70 kg

Shipping weight: 89 kg

Shipping volume: 0.94 m<sup>3</sup>

### Sustainability

Current consumption: 0.4 Amps

Noise level: 42 dBA